

JB series Memory Back-Up Use

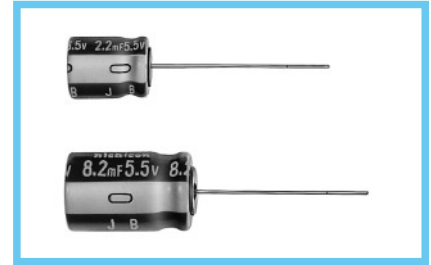

Anti-Solvent Feature

- Developed for memory back-up, with load life of 1000 hours at +85°C.
- Superior to electric double layer type capacitors in the following characteristics:
 - Better voltage maintenance.
 - Speedier charge-up available due to low impedance feature.
 - Wider operating temperature range of -25 to +85°C.
- Adapted to the RoHS directive (2002/95/EC).



Specifications

Item	Performance Characteristics																								
Category Temperature Range	-25 to +85°C																								
Rated Voltage Range	5.5V																								
Rated Capacitance Range	2.2 to 47mF See Note 1																								
Capacitance Tolerance	-10 to +50%																								
Leakage Current	C (μA) (C = Rated capacitance value in mF) See Note 2																								
Voltage Maintenance	More than 3.5V See Note 3																								
Stability at Low Temperature	Capacitance (-25°C) / Capacitance (20°C) × 100 ≥ 70%																								
Impedance (Ω) MAX. See Note 4	<table border="1"> <thead> <tr> <th>Capacitance (mF)</th> <th>2.2</th> <th>3.3</th> <th>4.7</th> <th>8.2</th> <th>10</th> <th>18</th> <th>22</th> <th>27</th> <th>33</th> <th>39</th> <th>47</th> </tr> </thead> <tbody> <tr> <td>Impedance (Ω)</td> <td>1.5</td> <td>1.0</td> <td>0.6</td> <td>0.3</td> <td>0.3</td> <td>0.2</td> <td>0.2</td> <td>0.2</td> <td>0.2</td> <td>0.1</td> <td>0.1</td> </tr> </tbody> </table>	Capacitance (mF)	2.2	3.3	4.7	8.2	10	18	22	27	33	39	47	Impedance (Ω)	1.5	1.0	0.6	0.3	0.3	0.2	0.2	0.2	0.2	0.1	0.1
Capacitance (mF)	2.2	3.3	4.7	8.2	10	18	22	27	33	39	47														
Impedance (Ω)	1.5	1.0	0.6	0.3	0.3	0.2	0.2	0.2	0.2	0.1	0.1														
Endurance	The specifications listed at right shall be met when the capacitors are restored to 20°C after the rated voltage is applied for 1000 hours at 85°C. <table border="1"> <tbody> <tr> <td>Capacitance change</td> <td>Within ±30% of initial value</td> </tr> <tr> <td>Impedance</td> <td>Within 4 times of initial specified value</td> </tr> <tr> <td>Leakage current</td> <td>Less than or equal to the initial specified value</td> </tr> <tr> <td>Voltage maintenance</td> <td>Satisfies initial specified value</td> </tr> </tbody> </table>	Capacitance change	Within ±30% of initial value	Impedance	Within 4 times of initial specified value	Leakage current	Less than or equal to the initial specified value	Voltage maintenance	Satisfies initial specified value																
Capacitance change	Within ±30% of initial value																								
Impedance	Within 4 times of initial specified value																								
Leakage current	Less than or equal to the initial specified value																								
Voltage maintenance	Satisfies initial specified value																								
Shelf Life	After storing the capacitors under no load at 85°C for 500 hours, and after performing voltage treatment based on JIS C 5101-4 clause 4.1 at 20°C, they will meet the requirements for endurance characteristics listed above.																								
Marking	Printed with white color letter on black sleeve.																								

Radial Lead Type

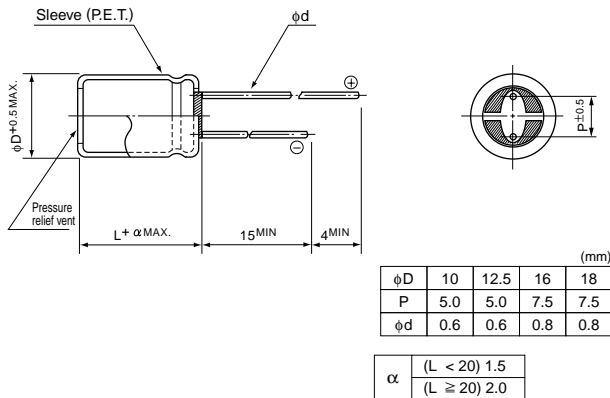

• Please refer to page 20 about the end seal configuration.

Type numbering system (Example : 5.5V 10mF)

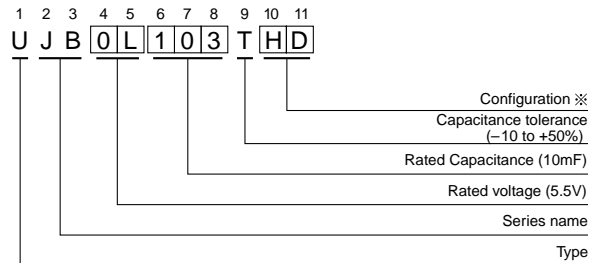

※ Configuration

φ D	Pb-free leadwire Pb-free PET sleeve
10	PD
12.5 to 18	HD

Note :

1. After charging a capacitor at the rated voltage of 5.5V for an hour, the capacitance is calculated by the following formula, measuring the time of duration, ΔT (Sec.) from 4V down to 3V when constant current discharge at i (mA) = 0.02 × nominal capacitance is carried out.

$$\text{Capacitance (mF)} = i \times \Delta T$$

2. Current value (20°C) after applying the rated voltage of 5.5V for an hour.
3. Voltage value maintained after the capacitor is subjected to 1 hour voltage application at 5V and then left at room temperature (lower than 25°C) for 24 hours.
4. Measuring Frequency : 1kHz (20°C)

Dimensions

Rated Voltage (V—mF)	Code	Case Size φD × L (mm)
5.5—2.2	0L222	10 × 12.5
5.5—3.3	0L332	10 × 16
5.5—4.7	0L472	10 × 20
5.5—8.2	0L822	12.5 × 20
5.5—10	0L103	12.5 × 25
5.5—18	0L183	16 × 25
5.5—22	0L223	16 × 31.5
5.5—27	0L273	16 × 35.5
5.5—33	0L333	18 × 31.5
5.5—39	0L393	18 × 35.5
5.5—47	0L473	18 × 40

Please refer to page 20, 21, 22 about the formed or taped product spec.
 Please refer to page 4 for the minimum order quantity.