



APPLICATION GUIDELINES FOR PLASTIC FILM CAPACITORS

1. Circuit Design

- (1) Please make sure the environmental and mounting conditions to which capacitor will be exposed are within the conditions specified in Nichicon's catalog (or alternate Nichicon specifications, such as series drawing).
- (2) Category Temperature and Humidity
 - ① In case that the category temperature is specified differently from store temperature, please follow the specific drawing.
 - ② Do not expose film capacitors to rapid temperature variations. Even if the range of change is within the specified limits.
 - ③ Do not use film capacitors in such high humidity conditions that result in the capacitor being exposed to water (including condensation).
- (3) When you choosing film capacitors for your circuit. Be sure the capacitor match the requirement of the application. If film capacitors are chosen in incorrectly, deterioration of the characteristics will be accelerated. Therefore, please chose the capacitor carefully.
- (4) Please contact out sales office. Prior to using film capacitors in applications other than those for which the capacitor was designed.
- (5) Unless otherwise specified, do not use film capacitors in the circuits requiring rapid and very frequent charge/discharge. Doing so may result in degrading or destruction of the capacitor.
- (6) Applying Voltage
 - ① Rated voltage of film capacitors designed for "AC" applications are marked with "VAC". In the case of capacitors designed for "DC" applications, only the voltage is marked.
 - ② "AC" rated capacitors (series: XL) must be used within a maximum of 110% of rated voltage including the input voltage variation.
 - ③ In case of "DC" voltage rated capacitors, the applied voltage shall be within a range where the peak value of ripple voltage (DC voltage + peak value of AC voltage) does not exceed the DC rated voltage. If there is a possibility that the applied voltage will exceed the rated voltage, please contact our sales office. In addition, if you use film capacitors in an ambient temperature condition that exceeds the category temperature range, the voltage should be derated in accordance with Fig. 1.
 - ④ In cases where you apply alternate voltage to XK, XK-(ZH),XP series, please refer to table1 for the allowable max AC voltage. As for XK-(ZH),XK and XP series, do not use in across-the-line application even with the derating.
 - ⑤ Do not use more than two (2) pieces of film capacitors in series.

Fig.1 Derating of Voltage and Operating Temperature

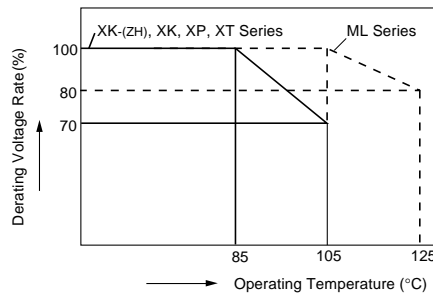

Table 1 Maximum Operating AC Voltage (at 50, 60Hz)

Rated Voltage	XK	XK-(ZH)	XP
100VDC	50VAC	—	—
250VDC	125VAC	125VAC	125VAC
400VDC	200VAC	200VAC	160VAC
630VDC	250VAC	250VAC	200VAC
800VDC	—	—	250VAC

- (7) Derating of Rated Voltage to High Frequency

When using the XK, XK-(ZH) or XP series in a high frequent circuit, please use the capacitor within the voltage limit calculated by the rated voltage multiplied by the coefficient listed in table 2.

However, be sure that effective current and the effective VA does not exceed the values specified in table 3 to 8.

Please consult our sales office, prior to operating capacitors at sinusoidal waves other than sine-wave. (In case of sinuous waves, the effective current and the effective VA values shall be calculated from peak voltage and current of applied current wave, pulse and frequency)

Table 2 Derating of Voltage at High Frequency

XK-(ZH), XK Series		XP Series	
Frequency	Derating Rate to 50/60Hz AC Rated voltage	Frequency	Derating Rate to 50/60Hz AC Rated voltage
50/60 (Hz)	100 (%)	50/60 (Hz)	100 (%)
1k	54	1k	76
5k	39	5k	55
10k	34	10k	49
20k	30	20k	41
30k	27	30k	38
40k	26	40k	36
50k	25	50k	35
60k	24	60k	33
70k	23	70k	32
80k	22	80k	31
90k	21	90k	30
100k	21	100k	30

Fig-2 ML Series f-Voltage Derating Curve

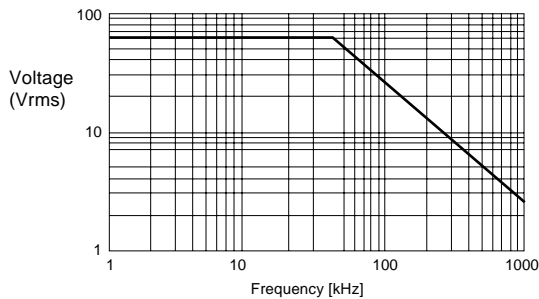

- (8) Permissible Current, VA value and Inherent Temperature Rise
- ① Do not use film capacitors in circuits that may exceed the maximum permissible current as specified in tables 3 to 8. The permissible current values will vary due to material and design, even though appearance is similar, therefore, please carefully confirm all parameters using the specification.
Also, if the capacitors to be subjected to a sinusoidal wave flow, please contact our sales office to select the proper capacitor.
 - ② The permissible VA value is restricted by the upper category temperature (ambient temperature + inherent temperature + radiant heat).
Do not use the capacitor in circuits which exceed the maximum permissible VA value specified in table 3 to 8. The permissible values will vary due to material and design, even though appearance is similar, therefore, please carefully confirm all parameters using the specification.
Also, if the capacitors to be subjected to a sinusoidal wave flow, please contact our sales office to select the proper capacitor.
 - ③ The inherent temperature under a no air flow shall be within the value listed below.
 XK-(ZH), XK series+10°C or below
 XP, XT series+5°C or below
 ML series+10°C or below
- (9) A "hum" may be produced under certain high frequency wave conditions. The "hum" does not effect the capacitor characteristics. Please consult our sales office if your application does not permit a "hum".
- (10) When designing circuit boards, please take into consideration how other parts would be affected should the capacitor develop a short or open circuit.

2. Mounting

- (1) Installation
- ① When installing capacitors, you must avoid any pulling, pushing or twisting stress to the leads or terminals.
 - ② Certain conditions, such as large capacitor body size or serious vibration, require the capacitor body to be affixed to the board using holders or resin coating. When using such materials, please be sure they do not effect the capacitor characteristics.
- (2) Soldering
- ① When soldering capacitors, avoid processes that require a long dwell time or high temperatures. Such conditions will result in deterioration of characteristics or short-circuit defects. Please ensure that the soldering process is within the range shown in the following Fig. 3.
 - ② When using a soldering iron to solder the capacitor, the soldering condition must be within the following specifications:
 Bit temperature: 350 ± 10°C
 Application time of soldering iron : 3 second
 - ③ If re-work is necessary, please wait until the capacitor temperature is equal to room temperature. Do not re-work more than twice.
 - ④ Please do not use Infrared-reflow as it will cause serious heat stress to the capacitor.

- ⑤ Prior to soldering film capacitors on the same PC board as chip type capacitors, please consult our sales office to confirm the compatibility of the soldering process.

Fig 3 Solder temp. and soldering time

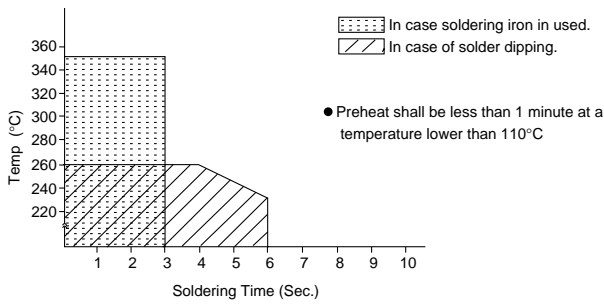

- (3) Soldering chip type
Soldering temperature and soldering time for chip type should be within limits as shown below when measured at capacitor top. Board size, distribution of reflow's temperature and capacitor's position on the circuit board will influence to reflow conditions. Please check real reflow condition before applying condition shown in fig.4

Fig. 4 Reflow temperature (Hot Air, Infrared Ray etc)

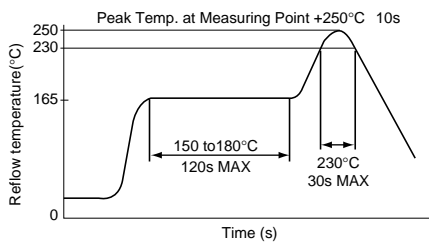

- Pre-heating shall be done at +150 – 180°C and for 120 seconds.
- The temperature at capacitor top shall not exceed +250°C.
- The duration for over +230°C temperature at capacitor top shall not exceed 30 seconds.
- Reflow shall be done within 2 cycles. Please make sure the parts have enough cooling down time between the first and second soldering process.
- The standard temperature profile differs by every reflow method.
- Please contact us if capacitors are subject to the conditions other than the allowable range of reflow.

- (4) Cleaning
 - ① If it is necessary to use cleaning agents to wash the board after soldering, please select alcohol based agents such as isopropyl alcohol.
 - ② Please wash the board as soon as possible after soldering.
 - ③ Please dry the board as soon as possible after cleaning.

3. In the equipment

- (1) Do not directly touch the terminal with your hand.
- (2) Do not short between terminals be conductor, nor spill conductible liquid such as alkaline nor acidic solution on or near the capacitor.
- (3) Please make sure that the ambient conditions where the set is installed will be free from spilling water or oil, direct sunlight, ultraviolet rays, radiation, poisonous gas, vibration or mechanical shock.

4. Maintenance and Inspection

- (1) If periodical inspection is required, please inspect the capacitor based on the specification of the drawings or catalog.

5. In an Emergency

- (1) If you see or smell smoke, immediately turn off the main switch or pull out the plug from the outlet.

6. Storage

- (1) Storage
 - ① Do not store the capacitor in high temperature or high humidity. The ambient storage conditions should be:
 - Temperature : -10 to +40°C
 - Humidity : lower than 75%
 - Place : indoor
 Ambient conditions to avoid;
 - quick temperature change
 - Exposure to spilling water or oil, direct sunlight, ultraviolet rays, radiation, poisonous gas such as hydrogen sulfide, sulfurous acid, nitrous acid, chorine, ammonium, etc..
 - ② Please store the capacitors in the original packed condition to avoid any physical stress to the capacitor.

- (2) Handling
- ① Do not apply excess vibration, mechanical shock (drop) or pressure to the capacitor.
 - ② Do not apply stress to the lead such as bending, pulling or twisting.

7. Disposal

- (1) Please dispose capacitors as industrial waste.

8. Other

- (1) Contents of this catalog (specifications, material, etc.) are subject to change without notice. Technical information (data) contained in this material is for description representation and application of the product and does not constitute any guarantee.
- (2) When ordering, please include the following information:
- ① Voltage to be applied ("DC" or "AC", ripple value)
 - ② Rated capacitance value and rated capacitance tolerance
 - ③ Category temperature range (inherent temperature + radiant heat should be included)
 - ④ Specific operating condition (wave form, effective current, dv/dt, etc.)
 - ⑤ Estimated failure mode
If the capacitor should fail, what effect will this have on the components or set.
If other components should fail, what effect will it have on the capacitor.
 - ⑥ Soldering condition (pre-heat condition, solder temperature, time, profile when chip parts are mounted on the same board)
 - ⑦ Set ambient condition (max. operating temperature, method of affixing, automobile use, existence of any gas surrounding capacitor)
- (3) Do not use parts provided as samples in sets for resale.

The above mentioned material is according to EIAJ RCR2350 B (issued in July 2002) titled "Guideline of notabilia for Fixed Plastic Film Capacitors for use in Electronic Equipment". Please refer to the book for details.

■ Type numbering system

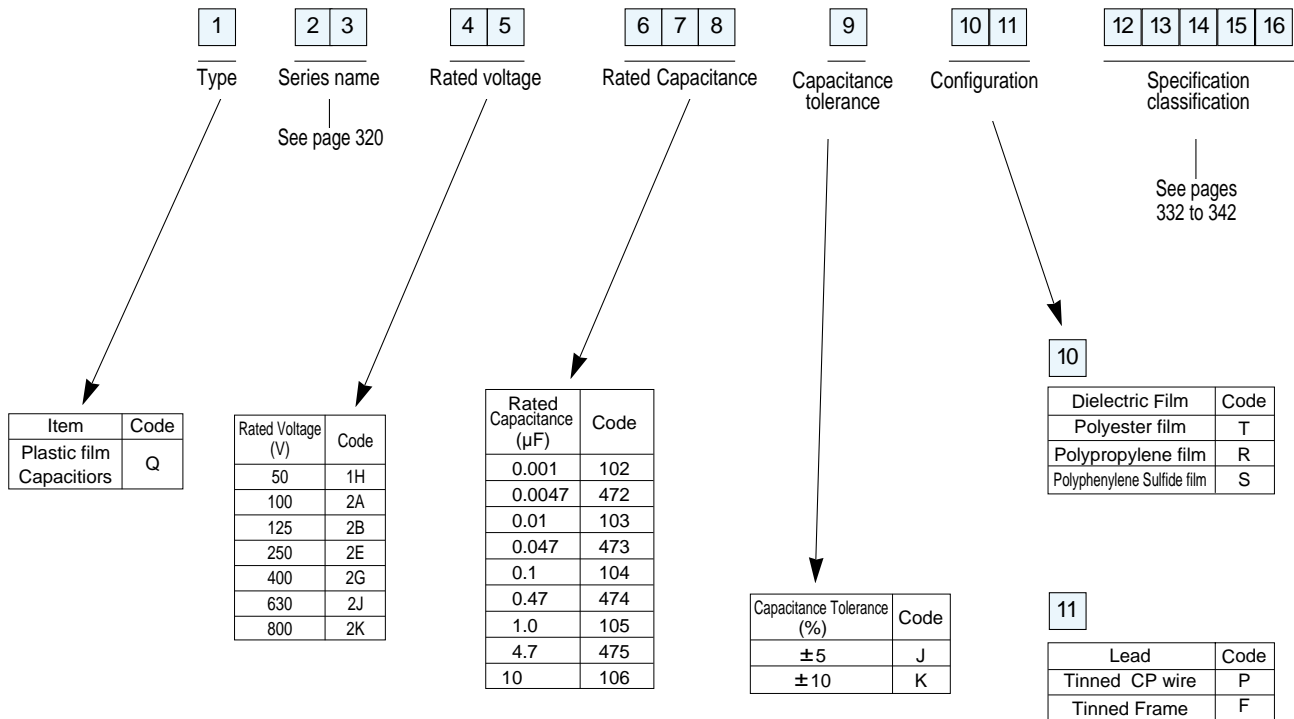

■ Type numbering system (Case Type)

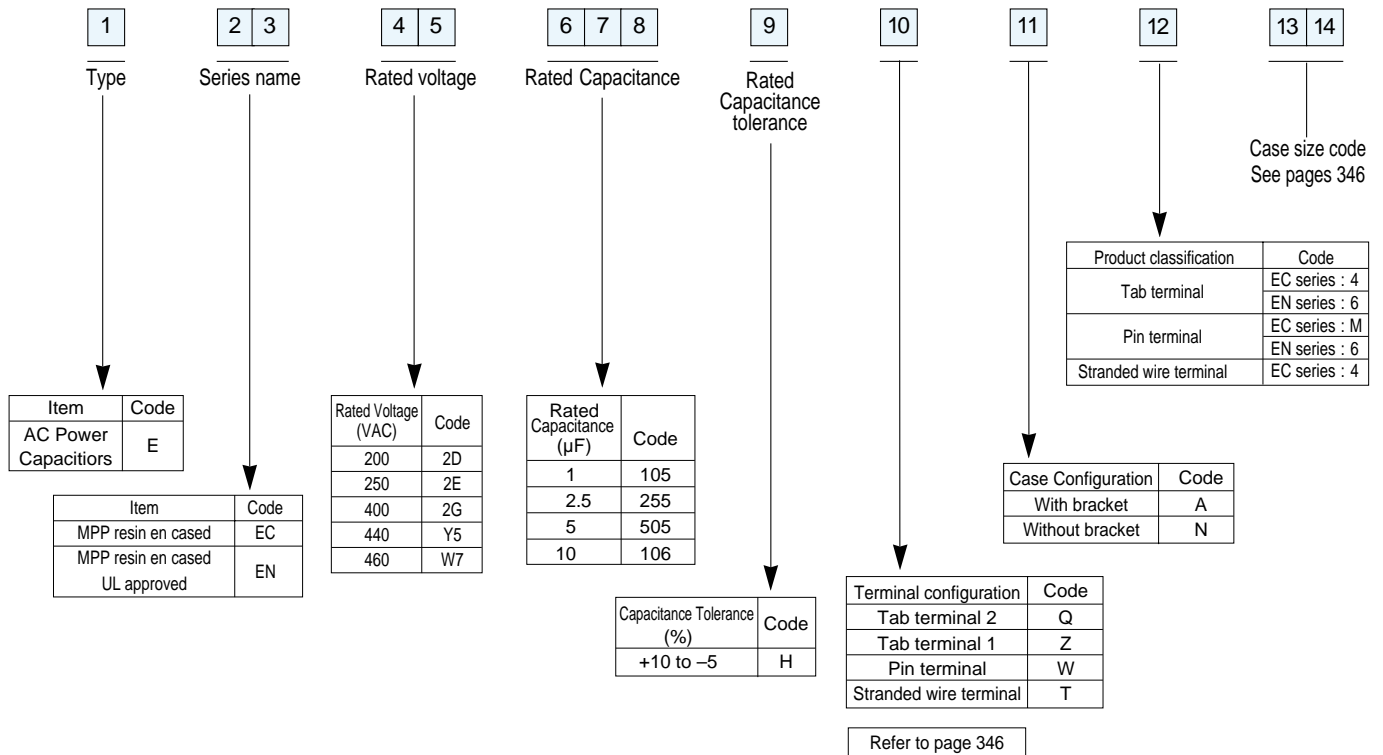

(Example) EC Series 250VAC 15μF

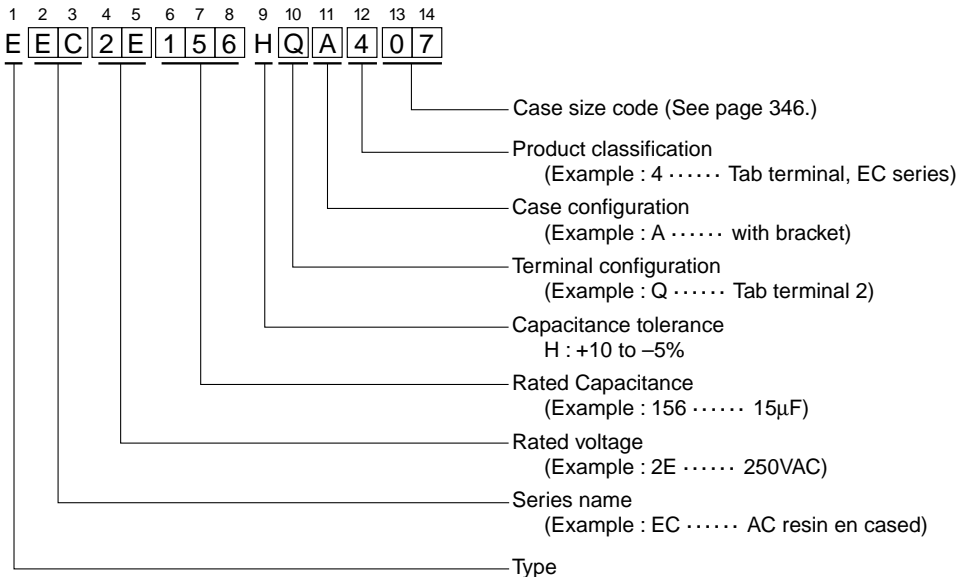

Table 3 XK-(ZH) Series Permissible Current and VA Value

Rated Capacitance (μF)	250VDC (2E)				400VDC (2G)				630VDC (2J)			
	Permissible Effective Current Ie (A)	Permissible Peak Current at Single Pulse Ip2 (A)	Permissible VA Value(Ie×Ve) Operating Temp. 85°C (VA) Operating Temp. 65°C (VA)		Permissible Effective Current Ie (A)	Permissible Peak Current at Single Pulse Ip2 (A)	Permissible VA Value(Ie×Ve) Operating Temp. 85°C (VA) Operating Temp. 65°C (VA)		Permissible Effective Current Ie (A)	Permissible Peak Current at Single Pulse Ip2 (A)	Permissible VA Value(Ie×Ve) Operating Temp. 85°C (VA) Operating Temp. 65°C (VA)	
0.01									0.1	1.0	2.6	11.2
0.015									0.15	1.5	2.9	12.5
0.022					0.2	2.0	2.3	10.2	0.25	2.5	3.2	14.2
0.033					0.25	2.5	2.6	11.4	0.3	3.0	3.8	16.6
0.047	0.3	3.0	2.2	9.8	0.3	3.0	2.9	12.6	0.3	3.0	4.3	18.6
0.068	0.35	3.5	2.2	9.8	0.45	4.5	3.3	14.3	0.45	4.5	5.0	21.8
0.1	0.4	4.0	2.5	10.9	0.45	4.5	3.8	16.4	0.6	6.0	5.6	24.6
0.15	0.5	5.0	2.9	12.6	0.6	6.0	4.5	19.6	0.7	7.0	7.2	31.4
0.22	0.85	8.5	3.3	14.3	0.8	8.0	5.1	22.5	1.0	10.0	8.4	36.9
0.33	0.9	9.0	3.8	16.6	1.3	13.0	6.1	26.9	1.5	15.0	10.1	44.3
0.47	1.0	10.0	4.5	19.8	1.5	15.0	7.2	31.4	1.6	16.0	11.0	52.7
0.68	1.5	15.0	5.3	23.0	1.8	18.0	9.0	39.4				
1.0	2.25	22.5	6.1	26.9	2.5	25.0	10.6	46.6				
1.5	2.4	24.0	7.9	34.8	3.0	30.0	13.0	56.8				
2.2	3.5	35.0	9.4	40.9								
3.3	4.0	40.0	11.5	50.2								

Table 4 XP Series Permissible Current and VA Value

Rated Capacitance (μF)	250VDC (2E)				400VDC (2G)				630VDC (2J)				800VDC (2K)			
	Permissible Effective Current Ie (A)	Permissible Peak Current at Single Pulse Ip2 (A)	Operating Temp. 85°C (VA)	Operating Temp. 65°C (VA)	Permissible Effective Current Ie (A)	Permissible Peak Current at Single Pulse Ip2 (A)	Operating Temp. 85°C (VA)	Operating Temp. 65°C (VA)	Permissible Effective Current Ie (A)	Permissible Peak Current at Single Pulse Ip2 (A)	Operating Temp. 85°C (VA)	Operating Temp. 65°C (VA)	Permissible Effective Current Ie (A)	Permissible Peak Current at Single Pulse Ip2 (A)	Operating Temp. 85°C (VA)	Operating Temp. Max.65°C (VA)
0.01									0.15	1.5	8	26	0.2	2.0	9	29
0.015									0.2	2.0	8	29	0.25	2.5	10	33
0.022					0.2	2.0	8	26	0.3	3.0	9	32	0.25	2.5	11	39
0.033					0.35	3.5	9	31	0.35	3.5	10	35	0.3	3.0	13	45
0.047	0.3	3.0	8	26	0.5	5.0	10	34	0.35	3.5	13	43	0.5	5.0	16	52
0.068	0.4	4.0	8	29	0.5	5.0	12	40	0.5	5.0	15	50	0.7	7.0	18	60
0.1	0.6	6.0	9	32	0.6	6.0	14	47	0.75	7.5	17	57	0.85	8.5	22	72
0.15	0.8	8.0	11	37	0.9	9.0	16	55	1.0	10.0	20	67	1.0	10.0	27	90
0.22	0.8	8.0	13	45	1.3	13.0	19	64	1.1	11.0	25	84	1.4	14.0	31	103
0.33	1.2	12.0	16	52	1.6	16.0	23	78	1.75	17.5	30	100	1.75	17.5	39	130
0.47	1.7	17.0	18	60	1.9	19.0	29	97	1.9	19.0	36	119	2.5	25.0	47	155
0.68	2.5	25.0	21	72	2.6	26.0	34	114	2.7	27.0	42	141				
1.0	2.6	26.0	28	92	3.1	31.0	42	139								
1.5	3.85	38.5	33	110	4.75	47.5	51	169								
2.2	4.4	44.0	41	135												
3.3	5.0	50.0	49	163												

Table 5 XK Series Permissible Current and VA Value

Rated Capacitance (μF)	250VDC (2E)				400VDC (2G)				630VDC (2J)			
	Permissible Effective Current Ie (A)	Permissible Peak Current at Single Pulse Ip2 (A)	Operating Temp. 85°C (VA)	Operating Temp. 65°C (VA)	Permissible Effective Current Ie (A)	Permissible Peak Current at Single Pulse Ip2 (A)	Operating Temp. 85°C (VA)	Operating Temp. 65°C (VA)	Permissible Effective Current Ie (A)	Permissible Peak Current at Single Pulse Ip2 (A)	Operating Temp. 85°C (VA)	Operating Temp. 65°C (VA)
0.01	0.1	1.0	1.2	5.2	0.1	1.0	1.2	5.2	0.08	0.8	1.8	7.9
0.015	0.1	1.0	1.2	5.2	0.1	1.0	1.3	5.5	0.10	1.0	2.0	8.9
0.022	0.15	1.5	1.3	5.5	0.15	1.5	1.5	6.4	0.15	1.5	2.5	10.6
0.033	0.15	1.5	1.4	5.9	0.15	1.5	1.7	7.6	0.15	1.5	2.9	12.5
0.047	0.15	1.5	1.4	5.9	0.2	2.0	2.1	9.0	0.2	2.0	3.2	14.0
0.068	0.25	2.5	1.6	6.8	0.25	2.5	2.4	10.4	0.25	2.5	3.8	16.3
0.1	0.35	3.5	1.9	8.1	0.3	3.0	2.8	12.3	0.3	3.0	4.8	21.0
0.15	0.4	4.0	2.3	9.9	0.35	3.5	4.0	17.2	0.5	5.0	6.1	26.4
0.22	0.6	6.0	2.6	11.5	0.5	5.0	4.5	19.6	0.6	6.0	6.5	28.2
0.33	0.6	6.0	3.3	14.3	0.7	7.0	5.0	21.5	0.7	7.0	7.9	34.4
0.47	0.7	7.0	4.2	18.2	0.8	8.0	6.3	27.1	0.9	9.0	9.3	40.1
0.68	1.0	10.0	5.2	22.7	0.9	9.0	7.4	31.9	1.3	13.0	11.1	48.0
1.0	1.4	14.0	6.1	26.5	1.2	12.0	8.7	37.6	1.5	15.0	12.9	55.8
1.5	1.6	16.0	6.7	29.1	1.5	15.0	10.3	44.5	2.0	20.0	15.9	69.0
2.2	1.8	18.0	8.1	35.3	2.2	22.0	12.3	53.5	3.0	30.0	19.0	82.0
3.3	2.5	25.0	9.8	42.6								
4.7	3.0	30.0	11.8	51.0								
6.8	3.0	30.0	13.7	59.3								
10.0	3.0	30.0	16.9	73.2								

■ Table 6 Example of current wave forms.

Item	Wave form diagram	Maximum	Effective value
Sine wave		I_m	$\frac{I_m}{\sqrt{2}}$
Half-wave rectification sine wave		I_m	$\frac{I_m}{2}$
Full-wave rectification sine wave		I_m	$\frac{I_m}{\sqrt{2}}$
Rectangular wave		I_m	I_m
Rectangular pulse wave		I_m	$I_m \sqrt{\frac{t_1}{T}}$
Isosceles triangular wave		I_m	$\frac{I_m}{\sqrt{3}}$
Saw tooth wave		I_m	$\frac{I_m}{\sqrt{3}}$
Trapezoidal wave		I_m	$I_m \sqrt{\frac{6t_2 - 2t_1}{3T}}$

■ Table 7 AK Series Permissible Current and VA Value

Rated Capacitance (μF)	250VDC (2E)				400VDC (2G)				630VDC (2J)			
	Permissible Effective Current $I_e(\text{A})$	Permissible Peak Current at Single Pulse $I_{p2}(\text{A})$	Permissible VA Value ($I_e \times V_e$)		Permissible Effective Current $I_e(\text{A})$	Permissible Peak Current at Single Pulse $I_{p2}(\text{A})$	Permissible VA Value ($I_e \times V_e$)		Permissible Effective Current $I_e(\text{A})$	Permissible Peak Current at Single Pulse $I_{p2}(\text{A})$	Permissible VA Value ($I_e \times V_e$)	
			Operating Temp. 85°C (VA)	Operating Temp. 65°C (VA)			Operating Temp. 85°C (VA)	Operating Temp. 65°C (VA)			Operating Temp. 85°C (VA)	Operating Temp. 65°C (VA)
0.1									0.5	5	6	26
0.15									0.8	8	7	33
0.22									1.1	11	8	38
0.33					1.4	14	7	30	1.7	17	10	46
0.47	1.1	11	4	20	1.7	17	8	35	1.8	18	12	53
0.68	1.6	16	5	24	1.9	19	9	38	2.1	21	14	62
1.0	2.3	23	7	30	2.8	28	10	46	2.5	25	17	77
1.5	2.5	25	8	34	3.5	35	13	59	3.5	35	22	95
2.2	3.0	30	9	40	3.5	35	15	68	4.0	40	25	110
3.3	4.0	40	11	50	4.5	45	19	85	5.5	55	32	138
4.7	4.5	45	13	59	5.0	50	22	97				
6.8	5.0	50	16	69								
10.0	5.5	55	19	85								

■ Table 8 AP Series Permissible Current and VA Value

Rated Capacitance (μF)	250VDC (2E)				400VDC (2G)				630VDC (2J)			
	Permissible Effective Current $I_e(\text{A})$	Permissible Peak Current at Single Pulse $I_{p2}(\text{A})$	Permissible VA Value ($I_e \times V_e$)		Permissible Effective Current $I_e(\text{A})$	Permissible Peak Current at Single Pulse $I_{p2}(\text{A})$	Permissible VA Value ($I_e \times V_e$)		Permissible Effective Current $I_e(\text{A})$	Permissible Peak Current at Single Pulse $I_{p2}(\text{A})$	Permissible VA Value ($I_e \times V_e$)	
			Operating Temp. 85°C (VA)	Operating Temp. 65°C (VA)			Operating Temp. 85°C (VA)	Operating Temp. 65°C (VA)			Operating Temp. 85°C (VA)	Operating Temp. 65°C (VA)
0.15									0.8	8	21	73
0.22									1.2	12	26	90
0.33					1.4	14	24	85	1.8	18	31	108
0.47	1.2	12	19	67	2.0	20	28	100	1.9	19	35	123
0.68	1.8	18	23	83	2.6	26	35	124	2.7	27	42	147
1.0	2.6	26	28	98	3.0	30	41	144	3.0	30	48	170
1.5	3.5	35	34	118	4.0	40	52	182	4.0	40	60	213
2.2	4.0	40	39	138	5.0	50	59	206	5.0	50	74	260
3.3	5.0	50	50	175	5.0	50	74	260	5.5	55	87	287
4.7	5.5	55	56	196	5.5	55	85	299				
6.8	5.5	55	69	223								
10.0	5.5	55	81	284								

■ Typical Characteristic Curves

Remarks: Typical curves are as shown below. (Slightly different depending on individual rating.)

■ Temperature Characteristics

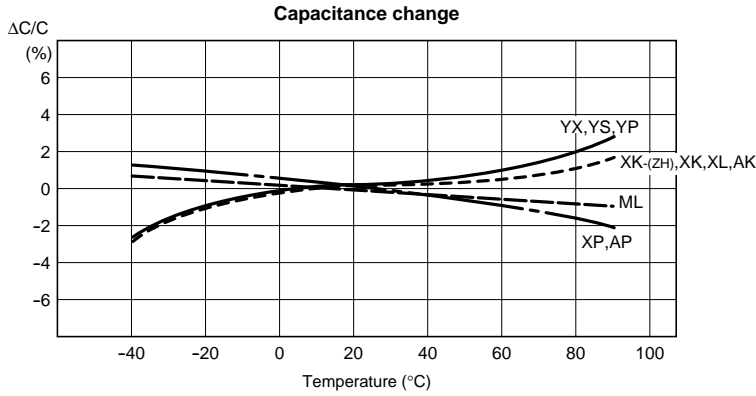

■ Frequency Characteristics

