



APPLICATION GUIDELINES FOR POSITIVE THERMISTORS, "Posi-R"

General Observations

1. Do not use "Posi-R" in the presence of oil or water. The parts could fail.
2. Do not apply voltage in excess of the rated voltage. This could cause a short circuit or burn-out.
3. Do not use "Posi-R" with reactive gas, reducing gas, or oxygen-free environment - electrical characteristics may deteriorate or burn-out may occur.

Notes on Usage

1. Please use the parts within the rated operating temperatures according to the catalog.
2. Please use the parts within the maximum operating voltage and maximum inrush current as specified in the catalog.
3. The surface temperatures for the "Posi-R" during operation are:
 - for degaussing 110 to 120°C
 - for overcurrent protection 100 to 160°CPlease take into consideration the effect of generated heat around the "Posi-R"
4. Excessive press or shock (ex. drop) should not be applied to the "Posi-R".
5. Do not apply more lead stress than specified.
6. Do not allow flux to come in contact with "Posi-R", it may cause failure.
7. The outer resin on the leads may be partially peeled off. This will not affect the function of products.

Notes on Storage

1. Packaged parts should be stored under the following conditions:
 - temperature: -10 to +40°C
 - humidity: 85% or less
2. Prolonged storage of "Posi-R" devices may result in increased resistive characteristics. They will return to the initial value by applying max. operating voltage prior to using the parts.
3. Shall be used shortly after opening the package. The prolonged exposure to the air may cause to deteriorate the solderability.

■ Characteristics of Positive Thermistors "Posi-R"

• Switching Temperature (Resistance Anomaly Point)

At the resistance / temperature characteristics of positive thermistors "Posi-R", the temperature which the resistance value becomes twice as high as that of at 25°C, is called as "switching temperature" (Curie point)
 Thermistors "Posi-R" show anomalous temperature characteristics of resistivity, and typical characteristics are represented in Fig. 1.
 Optimum characteristics can be selected for each application.

• Temperature Coefficient

The temperature coefficient is calculated from the linear range at the steepest portion of resistance (T₁ to T₂) as illustrated in Fig. 2.

$$\text{Temperature coefficient} = \frac{2.303 (\log_{10} R_2 / R_1)}{t_2 - t_1} \times 100 (\% / ^\circ\text{C})$$

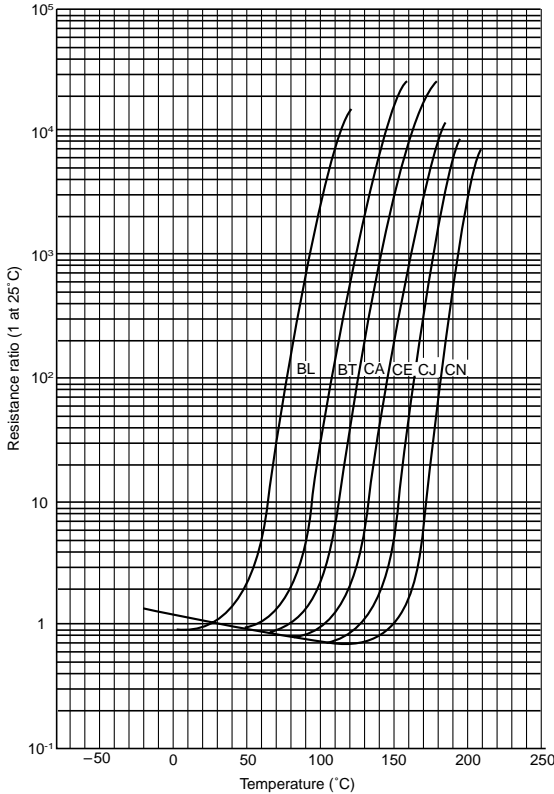

Fig. 1 Resistance / Temperature Characteristics

• Maximum Inrush Current

The maximum inrush current is the maximum allowable current (effective value) flowed into a Posi-R. No current higher than this shall be flowed as it causes breakdown of a Posi-R.

• Recovery Time

The recovery time is the time constant necessary for a Posi-R to quickly return to the switching temperature (resistance of twice as high as the initial value) after the power source is cut off.

• Dissipation Factor

When a power source is applied to Posi-R and thermal equilibrium will have been reached, the following equation is established.

$$V \cdot I = C (T_1 - T_0)$$

- Where, V : Applied voltage (V)
- I : Equilibrium current (A)
- C : Dissipation factor (W/°C)
- T₁ : Equilibrium temperature of Posi-R (°C)
- T₀ : Ambient temperature (°C)

In case that the dissipation factor is known by putting arbitrary values of voltage and current into the above equation, the equilibrium temperature at the then voltage can be attained.
 The temperature rise (T₁ - T₀) of Posi-R due to voltage application can be also computed easily

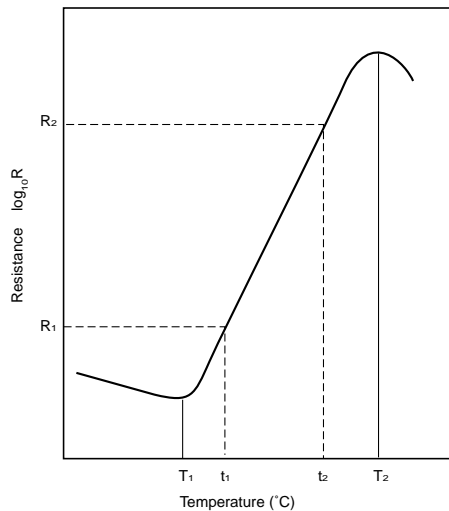

Fig. 2 Temperature Characteristics of "Posi-R"

• Voltage / Current Characteristics

In the Fig. 3 circuit, the relationship between voltage and current is called as the voltage/current characteristics when the voltage is applied to Posi-R and it gets the thermal equilibrium.

As seen in Fig. 4, the characteristic follows Ohm's law up to E₁ point. The current increases when the voltage is raised, provided that the temperature characteristics is within the range of switching temperature or lower. The range between E₁ and E₂ is over the switching temperature but within the constant range of power dissipation. However, beyond E₂ point, an excess power will run and Posi-R will result in breakdown, accordingly.

Therefore, the operating voltage of Posi-R shall be lower than E₂, and its rated voltage shall be defined to half of E₂ value or lower, taking the safety into account.

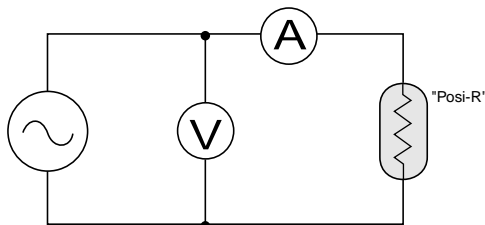

Fig. 3 Measuring Circuit

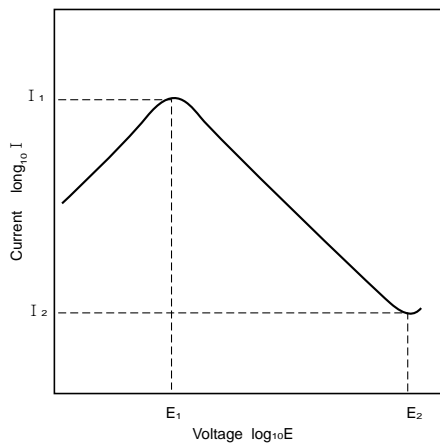

Fig. 4 Voltage / Current Characteristics

• Equilibrium Current, Equilibrium Resistance

The current, which Posi-R gets thermal equilibrium with an arbitrary voltage application (for 30 seconds or longer), is called as the equilibrium current.

Besides, the quotient which the applied voltage is divided by the equilibrium current is specified as the equilibrium resistance.

• Current , Time Characteristics

In the Fig. 5 circuit, when a load resistance (R) and a Posi-R are connected in series and an arbitrary voltage higher than E_1 in Fig. 4 is applied, the Posi-R will have inherent temperature due to a current flowing through it. Its temperature rises as time passes by, and it exceeds the switching temperature in a certain time, resulting in a rapid damp of the current. The trip time can be adjusted by the current volume as shown in Fig. 6.

By making use of these characteristics, a Posi-R can be used for the following applications;

1. Timing circuit
2. Switching use for motor starting
3. Overcurrent protection

When the parameters of I_1 , t_1 , I_2 and t_2 in Fig. 6 are expressed in a logarithmic graph in the manner of Fig. 7, an almost linear graph is formed and the relationship between the circuit current and the trip time can be obtained.

But, when a Posi-R is used for a timing application such as a timer, the voltage shall be appropriately applied for 30 seconds or less as the changes of conditions may affect much more as time passes by.

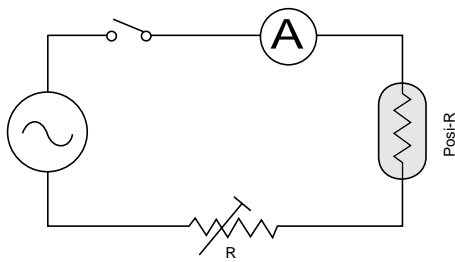

Fig. 5 Measuring Circuit

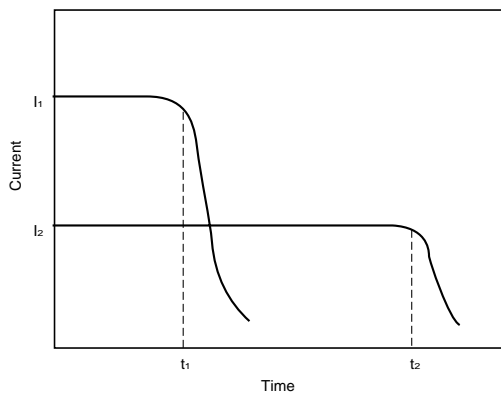

Fig. 6 Current / Time Characteristics

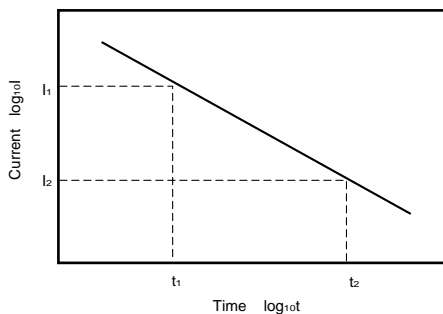
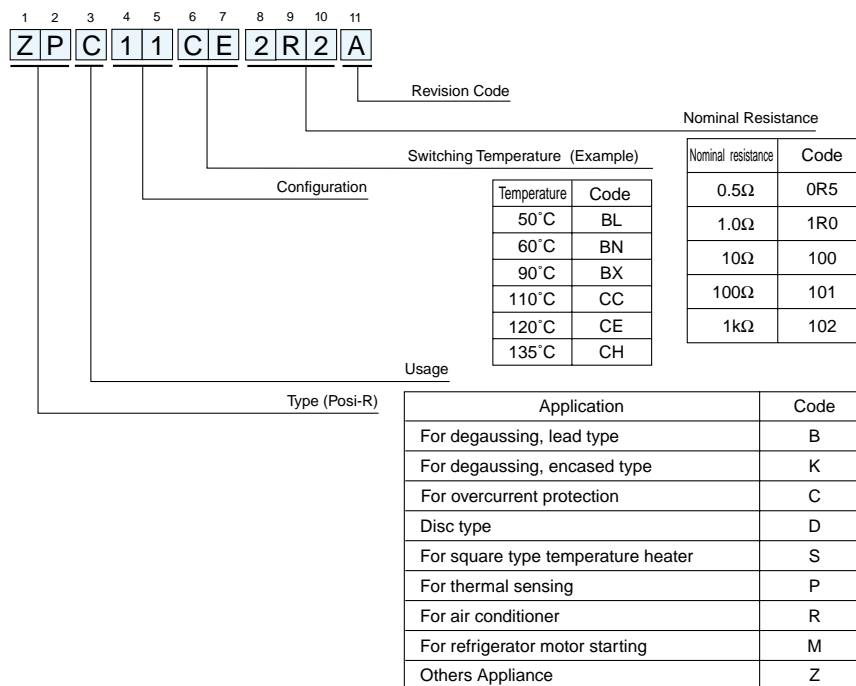

Fig. 7 Current / Time Characteristics

■ Type numbering system

(Example for overcurrent protection 12V. 2.2Ω)



■ For Overcurrent Protection

When something abnormal occurs at the load such as a transistor circuit or a small-type motor, an abnormal current rushes into the power source circuit. Then, a power transistor at the transformer or the switching power supply generates heat in an abnormal level and causes breakdown.

If a Posi-R for overcurrent protection is used in such a circuit, it can make the temperature compensation and protection for the power source and the load. An example is as shown in Fig. 8.

As to the temperature protection, it can be perfectly made in use of this Posi-R owing to the excellent characteristics of resistance anomaly, that is, a current is reduced by the increased resistance due to the selfheating of Posi-R.

At the voltage/current characteristics in Fig. 9, there is a peak current. If a current larger than this peak current flows, a Posi-R acts. But if a current less than the peak current flows, a Posi-R does not act. The peak current varies depending upon the size of Posi-R, resistance and ambient temperature. Fig. 10 shows an example of current characteristics.

At the current higher than the upper limit of fluctuation range, a Posi-R acts. Contrary, at the current less than the lower limit, it does not act. But the fluctuation range varies owing to ambient temperature.

For instance, if the operating temperature range is supposed to be at -10 to $+60^{\circ}\text{C}$, the lower limit at $+60^{\circ}\text{C}$ becomes the maximum value for a normal current (non-acting) and the upper limit at -10°C becomes the minimum value for a limiting current (acting), respectively.

Judging from the above explained relations, a Posi-R can be suited for the circuit where the ratio of a limiting current to a normal current is more than 2.5 to 3 times.

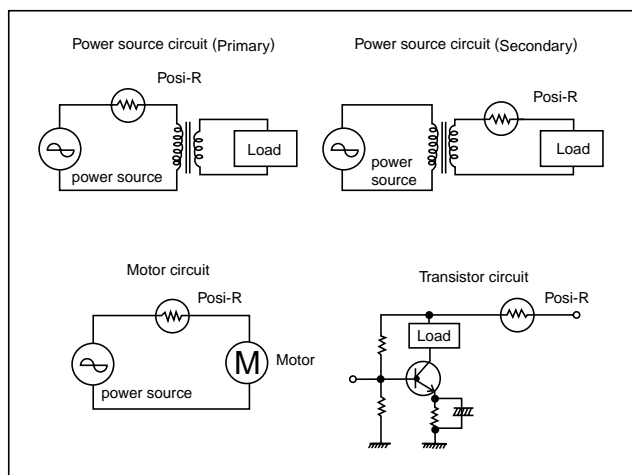

Fig. 8 Examples of applications

Characteristics of ZPC4MCE100D

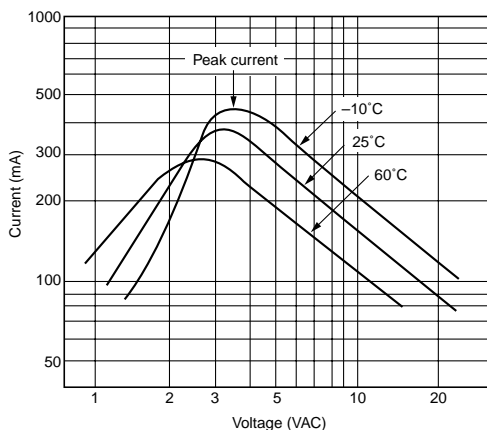

Fig. 9 Voltage / Current Characteristics

Characteristic of ZPC4MCE100D

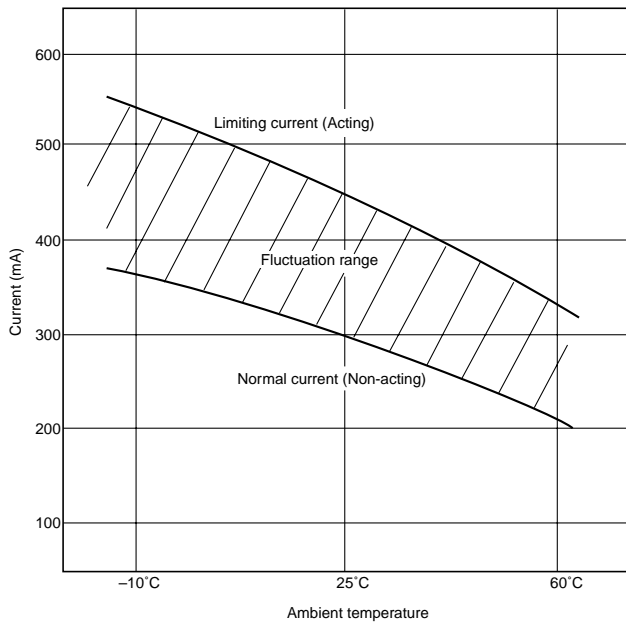

Fig. 10 Current Characteristics

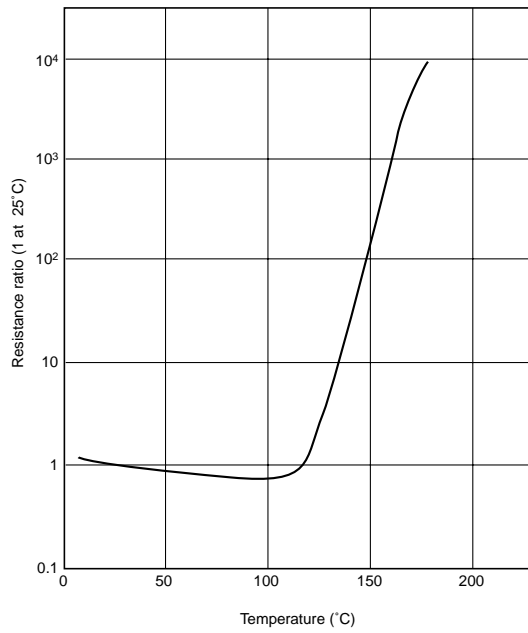

Fig. 11 Resistance / Temperature Characteristics