

■ Function Modules Technologies

Mount Technology Segment

Purpose and means

Application technology

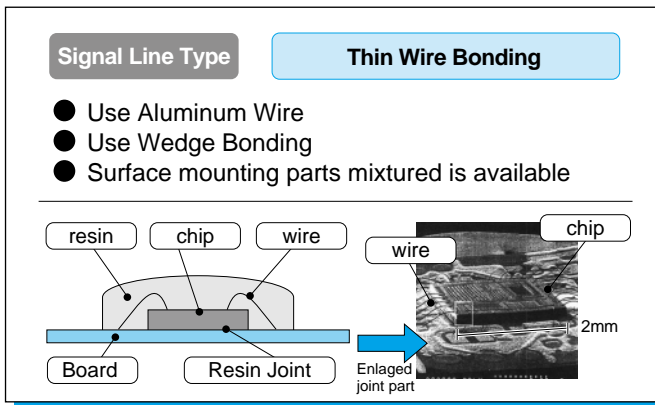
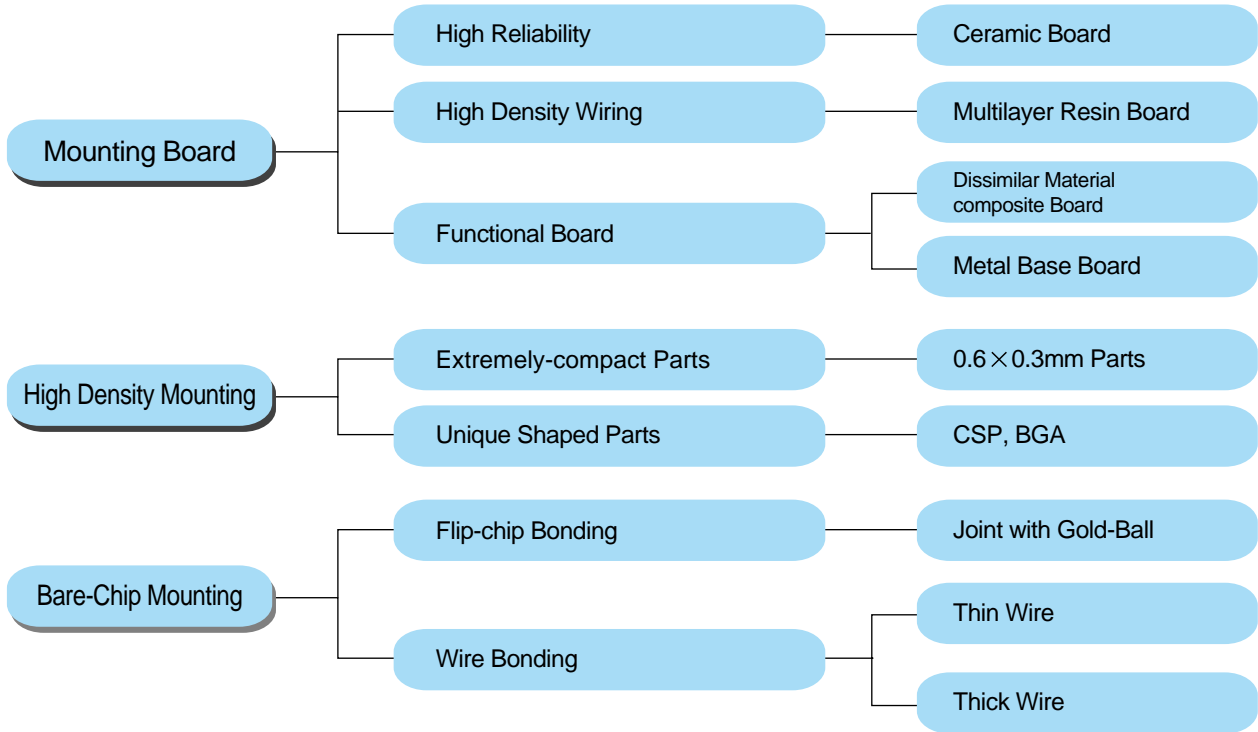

application case : Toner Quantity Sensor

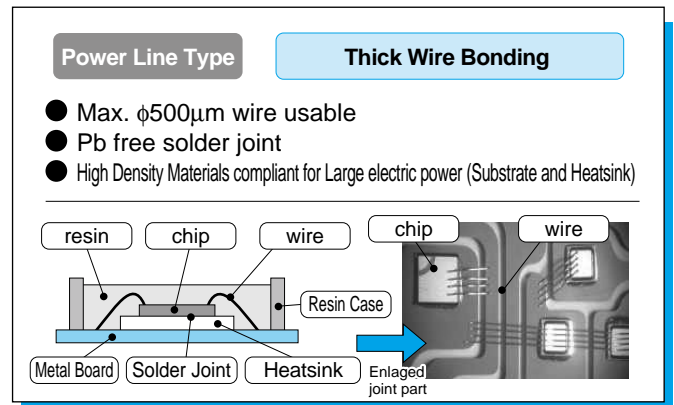
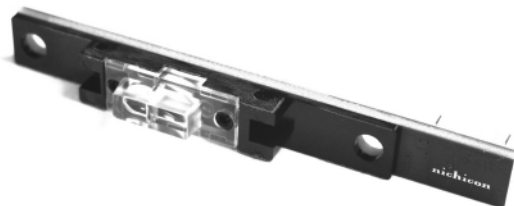

application case : Power Module

