

ALUMINUM ELECTROLYTIC CAPACITORS

MF 5mmL, Low Impedance series



- Low impedance over wide temperature range of -55 to +105°C, with 5mm height.
- Suited for DC-DC converters where smaller case size and lower impedance are required.
- Compliant to the RoHS directive (2002/95/EC).

MF ← Low Impedance MT

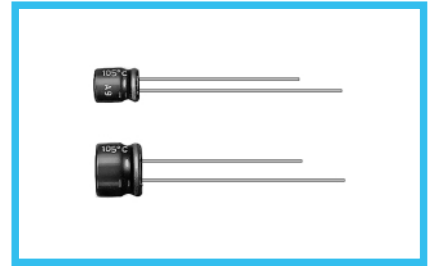

Specifications

Item	Performance Characteristics																			
Category Temperature Range	-55 to +105°C																			
Rated Voltage Range	6.3 to 35V																			
Rated Capacitance Range	1 to 100μF																			
Rated Capacitance Tolerance	±20% at 120Hz, 20°C																			
Leakage Current	After 2 minutes' application of rated voltage, leakage current is not more than 0.01CV or 3 (μA), whichever is greater.																			
Tangent of loss angle (tan δ)	Measurement frequency : 120Hz, Temperature : 20°C																			
	<table border="1"> <tr> <td>Rated voltage (V)</td> <td>6.3</td> <td>10</td> <td>16</td> <td>25</td> <td>35</td> </tr> <tr> <td>tan δ (MAX.)</td> <td>0.22</td> <td>0.20</td> <td>0.18</td> <td>0.14</td> <td>0.12</td> </tr> </table>	Rated voltage (V)	6.3	10	16	25	35	tan δ (MAX.)	0.22	0.20	0.18	0.14	0.12							
Rated voltage (V)	6.3	10	16	25	35															
tan δ (MAX.)	0.22	0.20	0.18	0.14	0.12															
Stability at Low Temperature	Measurement frequency : 120Hz																			
	<table border="1"> <tr> <td colspan="2">Rated voltage (V)</td> <td>6.3</td> <td>10</td> <td>16</td> <td>25</td> <td>35</td> </tr> <tr> <td rowspan="2">Impedance ratio ZT / Z20 (MAX.)</td> <td>Z-25°C / Z+20°C</td> <td>2</td> <td>2</td> <td>2</td> <td>2</td> <td>2</td> </tr> <tr> <td>Z-55°C / Z+20°C</td> <td>4</td> <td>4</td> <td>3</td> <td>3</td> <td>3</td> </tr> </table>	Rated voltage (V)		6.3	10	16	25	35	Impedance ratio ZT / Z20 (MAX.)	Z-25°C / Z+20°C	2	2	2	2	2	Z-55°C / Z+20°C	4	4	3	3
Rated voltage (V)		6.3	10	16	25	35														
Impedance ratio ZT / Z20 (MAX.)	Z-25°C / Z+20°C	2	2	2	2	2														
	Z-55°C / Z+20°C	4	4	3	3	3														
Endurance	The specifications listed at right shall be met when the capacitors are restored to 20°C after the rated voltage is applied for 1000 hours at 105°C.																			
	Capacitance change	Within ±20% of the initial capacitance value																		
	tan δ	200% or less than the initial specified value																		
Shelf Life	After storing the capacitors under no load at 105°C for 1000 hours and then performing voltage treatment based on JIS C 5101-4 clause 4.1 at 20°C, they shall meet the specified values for the endurance characteristics listed above.																			
		Leakage current	Less than or equal to the initial specified value																	
Marking	Printed with white color letter on dark brown sleeve.																			

Radial Lead Type

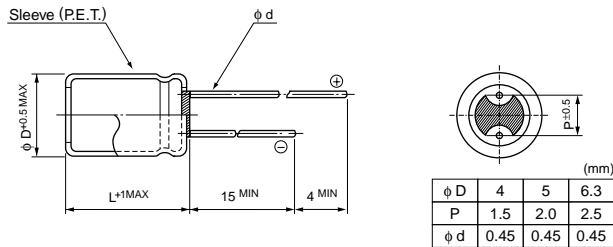

Type numbering system (Example : 25V 10μF)

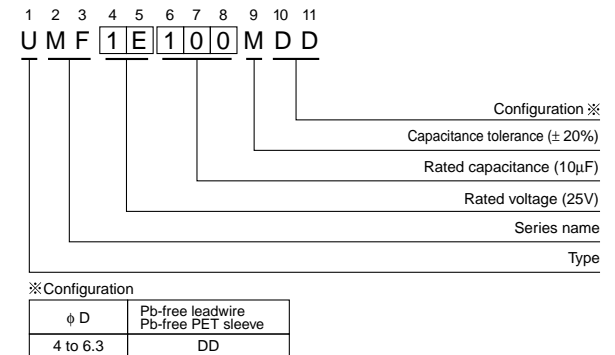

Dimensions

Cap.(μF)	Code	6.3			10			16			25			35		
		0J			1A			1C			1E			1V		
1	010													4×5	5.0	50
1.5	1R5													4×5	5.0	50
2.2	2R2													4×5	5.0	50
3.3	3R3													4×5	5.0	50
4.7	4R7										4×5	5.0	50	4×5	5.0	50
6.8	6R8										4×5	5.0	50	5×5	2.6	80
10	100							4×5	5.0	50	5×5	2.6	80	5×5	2.6	80
15	150							5×5	2.6	80	5×5	2.6	80	6.3×5	1.3	115
22	220	4×5	5.0	50	5×5	2.6	80	5×5	2.6	80	6.3×5	1.3	115	6.3×5	1.3	115
33	330	5×5	2.6	80	5×5	2.6	80	6.3×5	1.3	115	6.3×5	1.3	115			
47	470	5×5	2.6	80	6.3×5	1.3	115	6.3×5	1.3	115						
68	680	6.3×5	1.3	115												
100	101	6.3×5	1.3	115										Case size φD×L (mm)	Impedance	Rated ripple

Frequency coefficient of rated ripple current

Frequency	50 Hz	120 Hz	300 Hz	1 kHz	10 kHz or more
Coefficient	0.35	0.50	0.64	0.83	1.00

Max. Impedance (Ω) at 20°C 100kHz
 Rated ripple current (mArms) at 105°C 100kHz

Please refer to page 20, 21, 22 about the formed or taped product spec.
 Please refer to page 4 for the minimum order quantity.